

# STRAUB-OPEN-FLEX 4 | $\varnothing$ 323.9 - 4064.0 mm

Components / Materials	W1	W2	W4	W5
Casing	S355MC, hot-dip galvanised			AISI 316 L or similar
Bolts	AISI 4135			A4 - 80
Bars	AISI 12L14, galvanised			AISI 316 L or similar
Strip insert	AISI 301 / HDPE			AISI 316 L or similar / HDPE

**Sealing sleeve EPDM**  
 Temp.: -20°C up to +100°C  
 Medium: all qualities of water, waste water, air, solids and chemical products

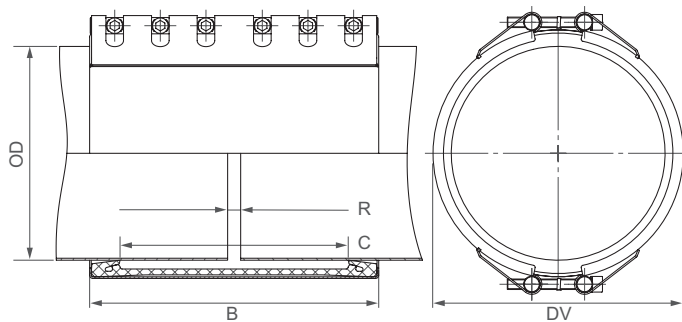

B  $\Rightarrow$  443 up to 444 mm  
 DV  $\Rightarrow$  OD + 48 mm  
 C  $\Rightarrow$  350 mm  
 R with strip insert  $\Rightarrow$  200 mm  
 R without strip insert  $\Rightarrow$  20 mm

	W1 or W5
	only in W5 available



OD [mm]	Clamping range [mm]	PN					
		2.5	6	10	16	20	25
323.9	320 - 327						
355.6	352 - 359						
406.4	403 - 409						
457.2	454 - 460						
508.0	505 - 512						
558.8	555 - 562						
609.6	606 - 613						
655.0	652 - 658						
711.2	707 - 715						
762.0	758 - 766						
812.8	809 - 817						
914.4	910 - 918						
1016.0	1012 - 1020						
1117.6	1113 - 1122						
1219.2	1215 - 1224						
1320.8	1316 - 1325						
1422.4	1418 - 1427						
1524.0	1519 - 1529						
1600.0	1595 - 1605						
1625.0	1621 - 1631						
1727.2	1722 - 1732						
1828.8	1824 - 1834						
1930.4	1925 - 1935						
2032.0	2027 - 2037						
2268.0	2263 - 2273						
2540.0	2535 - 2545						
2794.0	2798 - 2799						
3048.0	3043 - 3053						
3302.0	3296 - 3308						
3556.0	3548 - 3562						
3810.0	3804 - 3816						
4064.0	4058 - 4070						

CONTINUOUSLY VARIABLE INTERMEDIATE SIZES FROM 323.9 TO 4064.0 mm ARE AVAILABLE

## Remarks:

- Follow fitting instructions
- PN = working pressure considering the application loads  
 Test pressure = PN x 1.5 (for example industry, water supply etc.)
- Strip inserts included
- Additional sealing sleeves, pressure and temperature ranges on request

## Versions:

PN						2 piece casing [mm]	3 piece casing [mm]
2.5	6	10	16	20	25		
x	x	x	x	x	x	$\leq 3048.0$	$> 3048.0$

$\Rightarrow$  pressure rating definition, see above