

STRAUB-FLEX 3 | \varnothing 219.1 - 2032.0 mm

Components / Materials	W1	W2	W4	W5
Casing	S355MC, hot-dip galvanised	AISI 316 L or similar		AISI 316 L or similar
Bolts	AISI 4135	AISI 4135		A4 - 80
Bars	AISI 12L14, galvanised	AISI 12L14, galvanised		AISI 316 L or similar
Strip insert (option)	AISI 316 L or similar / HDPE	AISI 316 L or similar / HDPE		AISI 316 L or similar / HDPE
Sealing sleeve EPDM	Temp.: -20°C up to +100°C Medium: all qualities of water, waste water, air, solids and chemical products			
Sealing sleeve NBR	Temp.: -20°C up to +80°C Medium: water, gas, oil, fuel and other hydrocarbons			
Sealing sleeve FPM/FKM (on request)	Temp.: -20°C up to +180°C Medium: ozone, oxygen, acids, gas, oil and fuel (only with strip insert)			

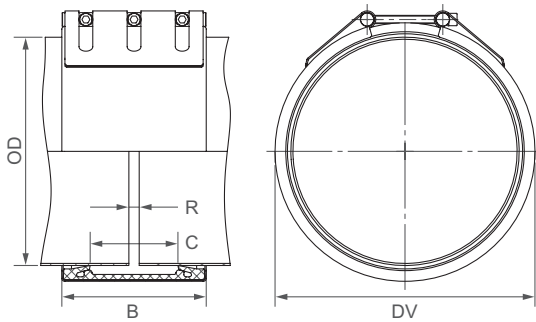

B \Rightarrow 210 up to 218 mm
 DV \Rightarrow OD + 38 mm
 C \Rightarrow 127 mm
 R with strip insert \Rightarrow 60 mm
 R without strip insert \Rightarrow 15 mm

	W2 or W5
	W1, W2 or W5
	W1 or W5
	only in W1 available



OD [mm]	Clamping range [mm]	PN					
		2.5	6	10	16	20	25
219.1	216 - 222						
250.0	247 - 253						
267.0	264 - 270						
273.0	270 - 276						
304.0	301 - 307						
323.9	321 - 327						
355.6	352 - 358						
406.4	403 - 409						
457.2	454 - 460						
508.0	504 - 512						
558.8	555 - 562						
609.6	606 - 613						
711.2	707 - 715						
762.0	758 - 766						
812.8	809 - 817						
914.4	910 - 918						
1016.0	1012 - 1020						
1117.6	1113 - 1122						
1219.2	1215 - 1224						
1320.8	1316 - 1325						
1422.4	1418 - 1427						
1524.0	1519 - 1529						
1600.0	1595 - 1605						
1625.6	1621 - 1631						
1727.2	1722 - 1732						
1828.8	1824 - 1834						
1930.4	1925 - 1935						
2032.0	2027 - 2037						

CONTINUOUSLY VARIABLE INTERMEDIATE SIZES FROM 219.1 TO 2032.0 mm ARE AVAILABLE

Remarks:

- Follow fitting instructions
- PN = working pressure considering the application loads
Test pressure = PN x 1.5 (for example industry, water supply etc.)
Burst pressure = approx. PN x 2
- Strip inserts are optional accessories (see Technical Manual STRAUB)
- Additional sealing sleeves, pressure and temperature ranges on request

\Rightarrow Bigger diameters are available as STRAUB-OPEN-FLEX