

STRAUB-OPEN-FLEX 3 | ∅ 219.1 - 4064.0 mm

Components / Materials	W1	W2	W4	W5
Casing	S355MC, hot-dip galvanised	AISI 316 L or similar		AISI 316 L or similar
Bolts	AISI 4135	AISI 4135		A4 - 80
Bars	AISI 12L14, galvanised	AISI 12L14, galvanised		AISI 316 L or similar
Strip insert (option)	AISI 316 L or similar / HDPE	AISI 316 L or similar / HDPE		AISI 316 L or similar / HDPE
Sealing sleeve EPDM	Temp.: -20°C up to +100°C Medium: all qualities of water, waste water, air, solids and chemical products			
Sealing sleeve NBR	Temp.: -20°C up to +80°C Medium: water, gas, oil, fuel and other hydrocarbons			
Sealing sleeve FPM/FKM (on request)	Temp.: -20°C up to +180°C Medium: ozone, oxygen, acids, gas, oil and fuel (only with strip insert)			

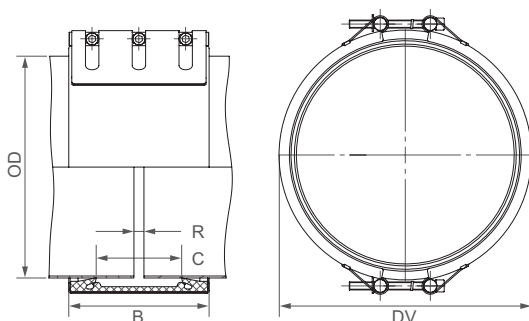

B ⇨ 210 up to 218 mm
 DV ⇨ OD + 38 mm
 C ⇨ 127 mm
 R with strip insert ⇨ 60 mm
 R without strip insert ⇨ 15 mm

	W2 or W5
	W1, W2 or W5
	W1 or W5
	only in W1 available



OD [mm]	Clamping range [mm]	PN					
		2.5	6	10	16	20	25
219.1	215 - 224						
250.0	246 - 255						
267.0	263 - 272						
273.0	269 - 278						
304.0	300 - 309						
323.9	320 - 329						
355.6	350 - 360						
406.4	402 - 411						
457.2	453 - 462						
508.0	502 - 514						
558.8	553 - 564						
609.6	604 - 615						
711.2	705 - 717						
762.0	756 - 768						
812.8	807 - 819						
914.4	908 - 920						
1016.0	1010 - 1022						
1117.6	1111 - 1125						
1219.2	1213 - 1226						
1320.8	1314 - 1328						
1422.4	1416 - 1429						
1524.0	1517 - 1532						
1600.0	1593 - 1608						
1625.6	1619 - 1634						
1727.2	1720 - 1735						
1828.8	1822 - 1837						
1930.4	1923 - 1938						
2032.0	2025 - 2040						
2268.0	2261 - 2276						
2540.0	2533 - 2548						
2794.0	2787 - 2802						
3048.0	3041 - 3056						
3302.0	3293 - 3311						
3556.0	3544 - 3566						
3810.0	3801 - 3819						
4064.0	4055 - 4073						

CONTINUOUSLY VARIABLE INTERMEDIATE SIZES FROM 219.1 TO 4064.0 mm ARE AVAILABLE

Remarks:

- Follow fitting instructions
- PN = working pressure considering the application loads
Test pressure = PN x 1.5 (e.g. industry, water supply etc.)
- Strip inserts are optional accessories (see Technical Manual STRAUB)
- Additional sealing sleeves, pressure and temperature ranges on request
- From ∅ 3048 in 3-part design

